

## 3000/3200 Series

### RATINGS

		Input Torque Gross N•m (lb-ft)	Input Power Gross <sup>1</sup> Kw (hp)	Turbine Torque Net <sup>2</sup> N•m (lb-ft)	GVW kg (lbs)	GCW kg (lbs)
3000	General	1261 (930)	254 (340)	2108 (1555)	n/a	n/a
	Refuse, Concrete Mixer	1186 (875)	239 (320)	2034 (1500)	28,500 (62,832)	n/a
	Fire Truck, Emergency	1424 (1050)	261 (350)	2169 (1600)	n/a	n/a
	Dock Spotter, Tow Tractor	1261 (930)	246 (330)	2108 (1555)	n/a	36,288 (80,000)
	School Bus, Outside N.A.	1254 (925)	224 (300)	1857 (1370)	20,415 (45,000)	n/a
	Ag Spreader, Sprayer, Blower, Feedlot Truck	1288 (950)	235 (315)	2108 (1555)	n/a	n/a
3000 SP	Specialty Vehicles	1322 (975)	254 (340)	2135 (1575)	n/a	n/a
	Military Support and Tactical	1322 (975)	254 (340)	2135 (1575)	n/a	n/a
	Military Combat	1424 (1050)	261 (350)	2169 (1600)	n/a	n/a
3200	General	1491 (1100)	276 (370)	2169 (1600)	n/a	n/a
	Refuse, Concrete Mixer	1491 (1100)	276 (370)	2169 (1600)	28,500 (62,832)	n/a
	Fire Truck, Emergency	1695 (1250)	316 (425)	2305 (1700)	n/a	n/a
	Ag Spreader, Sprayer, Blower, Feedlot Truck	1695 (1250)	276 (370)	2305 (1700)	n/a	n/a
3200 MH	Motorhome	1695 (1250)	316 (425)	2305 (1700)	n/a	n/a
3200 ORS	Articulated Dump	1100 (811)	224 (300)	2135 (1575)	44,500 (98,100)	n/a
	Rigid Dump	1100 (811)	224 (300)	2135 (1575)	44,500 (98,100)	n/a
	Off-Road	CONTACT YOUR ALLISON REPRESENTATIVE FOR DETAILS				
3200 SP	Specialty Vehicles	1627 (1200)	298 (400)	2305 (1700)	n/a	n/a
	Military Support and Tactical	1695 (1250)	298 (400)	2305 (1700)	n/a	n/a
	Military Combat	1695 (1250)	316 (425)	2305 (1700)	n/a	n/a

1. Gross Power rating as defined by ISO 1585 or SAE J1995. 2. Turbine Torque limit based on iSCAN standard deductions.

### DRIVETRAIN INTERFACES

Acceptable full-load engine governed speed	2000 – 2800 rpm
Acceptable engine idle speed range (with transmission in Drive)	500 – 820 rpm
Maximum output shaft speed at 105 km/hr (65 mi/hr) – retarder-equipped models only	3600 rpm

### MOUNTING

To Engine	SAE No.2
In Chassis	Rear support available (required for some installations)

### TORQUE CONVERTER

<b>Type</b>	One stage, three element, polyphase. Includes standard integral damper which is operational in lockup.
<b>Model</b>	<b>Stall Torque Ratio</b>
TC-411	2.71
TC-413	2.44
TC-415	2.35
TC-417	2.20
TC-418	1.98
TC-419	2.02
TC-421	1.77

### MECHANICAL RATIOS (Gear ratios do not include torque converter multiplication)

<b>Range</b>	
First	3.49 : 1
Second	1.86 : 1
Third	1.41 : 1
Fourth	1.00 : 1
Fifth	0.75 : 1
Sixth	0.65 : 1
Reverse	-5.03 : 1

## CONTROL SYSTEM

<b>Description</b>	Allison 4th Generation Electronic Controls with closed loop adaptive shifts
<b>Shift Sequences</b>	[C = Converter mode (lockup clutch disengaged); L = Lockup mode (lockup clutch engaged)] Option 1: 1C-[1L]-2C-2L-3L-4L Option 2: 1C-[1L]-2C-2L-3L-4L-5L Option 3: 1C-[1L]-2C-2L-3L-4L-5L-6L
<b>Driver-to-Transmission Interface</b>	Cab-mounted shift selector, pushbutton or lever with two-digit display (range selected and range attained)
<b>Communication Protocol - Engine/Vehicle Systems Interface</b>	SAE J1939, SAE J1587, ISO 9141, IESCAN

## PHYSICAL DESCRIPTION

	Length*	Dry weight	Depth below transmission centerline	
			With Shallow Oil Sump (Standard)	With Deep Oil Sump (Optional)
Basic Model	740 mm (29 in)	243 kg (535 lbs)	283 mm (11.5 in)	328 mm (12.9 in)
With PTO Drive Provision	846 mm (33.2 in)	260 kg (575 lbs)	283 mm (11.5 in)	328 mm (12.9 in)
With Retarder	740 mm (29 in)	280 kg (615 lbs)	283 mm (11.5 in)	328 mm (12.9 in)
With PTO Drive Provision and Retarder	846 mm (33.2 in)	300 kg (655 lbs)	283 mm (11.5 in)	328 mm (12.9 in)

\*Approximate length from engine housing to output flange (depending on output flange type)

## ENGINE-DRIVEN POWER TAKE-OFF PROVISION

Mounting pad positions viewed from rear	Drive gear rating with one PTO N•m (lb-ft)	Drive gear rating with two PTOs N•m (lb-ft)	PTO Drive Gear	Drive
4 o'clock and 8 o'clock (Standard)	660 (485)	930 (685)	68 tooth	Engine
1 o'clock and 8 o'clock (Optional)	660 (485)	930 (685)	83 tooth	Engine
Fire and Emergency	910 (670)	930 (685) <sup>1</sup>		

<sup>1</sup> Intermittent rating to 1068 N•m

## OUTPUT RETARDER PROVISION (OPTION)

Type	Integral, hydraulic		
	Torque	Capacity	Power
Level 3	2170 N•m (1600 lb-ft)		447 kW (600 hp)
Level 2	1760 N•m (1300 lb-ft)		373 kW (500 hp)
Level 1	1490 N•m (1100 lb-ft)		298 kW (400 hp)

## OIL SYSTEM

Oil type	Transynd™, DEXRON®-III
Capacity, excluding external circuits	
With Deep Oil Sump	27 litres (29 quarts)
With Shallow Oil Sump	25 litres (26 quarts)
Main circuit oil filter	Replaceable element, integral
Cooler circuit oil filter	Replaceable element, integral
Electronic oil level sensor (OLS)	Standard

## SPEEDOMETER PROVISION

<b>Description</b>	Non-zero-crossing square wave
	8, 16 or 40 pulses per revolution of transmission output shaft
<b>Location</b>	Electronic output from TCM

## TACHOGRAPH PROVISION

<b>Tone wheel</b>	4 or 6-tooth
<b>Mounting</b>	M18 x 1.5 metric thread
<b>Location</b>	Transmission rear cover or retarder housing

### 3000/3200 Series With Shallow Sump and PTO

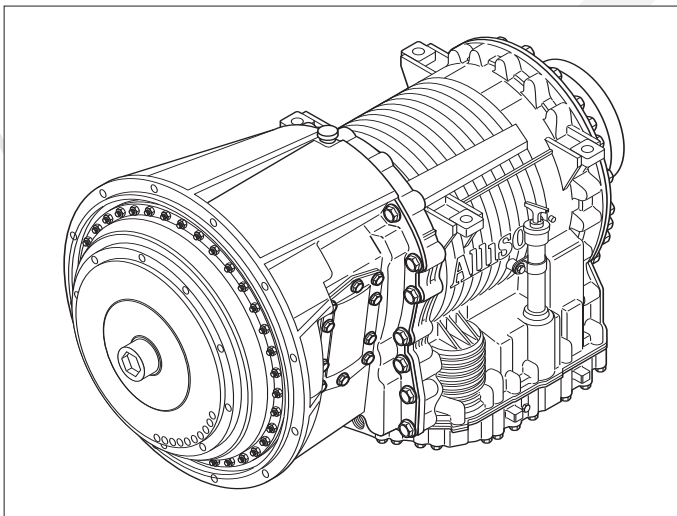

### 3000/3200 Series With Retarder, PTO and Deep Oil Sump

